

# Bakfiets.nl



2023

*sinds 1999*

has changed the look of cycling in the Netherlands, United Kingdom and many other countries. Their concept of carrying children in a cargo bike was innovative and is now accepted world-wide as an alternative and green form of transport. For many parents using a Bakfiets.nl Cargobike or Cargotrike is a liberating and life changing experience especially on the school run in busy towns and cities where the volume of traffic has become a big problem. Since the first model, there has been continuing development to enable you to carry babies, children, dogs, shopping and cargo with ease and in safety.



## → Electric Assist

Almost all CargoBikes and Trikes are available with an electric driven assist motor. This makes cycling more comfortable (lighter and faster). The motor can also be used to assist you while pushing the bike.

The battery can be placed in the rear rack or mounted on the box and is removable.

## → Shimano STEPS

All the Cargobikes and Trikes make use of the Shimano Steps (DU6100). This powerful motor is light and reliable, and is located at the bottom bracket. The motor has a good range and long battery life. The handlebar mounted display is simple to use and has a handlebar mounted toggle switch to change between the functions and power settings. There is even a walk function for pedestrianised areas when dismounted. The STEPS system delivers standard **50Nm**, with the Enviolo and Shimano nexus 5 hub even **60Nm, with 250w**.

### Available gear options

Steps is available in combination with different gear options: Shimano Nexus 7 speed with Rollerbrakes, Shimano Di2 5 speed hub with electronic gear changer and the Shimano rollerbrakes Enviolo continuously variable hub gear with rollerbrakes

### Nexus 5 speed hub

This hub is specially made for use in cargo bikes combined with a mid-engine. It has a sturdier build so it can withstand more force than a nexus 7 or 8 speed hub (see page 17 for more information).

### Di2

The Di2 version is fully integrated with the motor and by means of electronic control the motor automatically reduces power slightly to enable smooth electronic gear shifting. The system automatically shifts down when coming to a halt therefore you are in the right gear to set off again. Or you can choose to manually select the gears with the toggle switch on the handlebar.

### Battery

We deliver the bikes standard with a 418Wh battery, optionally there can be chosen for the upgraded 504Wh version, which has a 20% larger operating range.

## → Operating Range

**Pay attention:** for a Cargobike its hard to specify the exact operation range. The operation range can vary between 25 km and 70 km (15 and 50 miles). This depends on the total weight (rider + load) of the Cargobike, the level of assistance chosen from the motor. The terrain to be covered—flat—hilly or mountainous. City or country environments will have a big influence, stopping and starting especially. Its possible to increase the operation range by driving away in a low gear and by making sure that the tires are inflated.



## → Bafang M400

The electric CargoBikes long and Trikes can be equipped with the Bafang mid-engine system (M400 series). This system is relatively light in weight, provides good support and has a large range. Bafang has become a major player in the field of electric bicycles, the motor delivers no less than 80Nm at 250 watts, making it a more powerful motor than the Shimano 6100 series.

### Available gear options

The Bafang models are available with a NuVinci stepless gear hub or a Shimano nexus 5 gear hub manual transmission.

### Nexus 5 versnellingsnaaf

This hub is specially made for use in cargo bikes combined with a mid-engine. It has a sturdier build so it can withstand more force than a nexus 7 or 8 speed hub (see page 17 for more information).

### Battery

The Bafang bicycles are supplied with a large 750Wh battery as standard.

## → Operating Range

**Pay attention:** for a Cargobike its hard to specify the exact operation range. The operation range can vary between 35 km and 90 km (15 and 50 miles). This depends on the total weight (rider + load) of the Cargobike, the level of assistance chosen from the motor. The terrain to be covered—flat—hilly or mountainous. City or country environments will have a big influence, stopping and starting especially. Its possible to increase the operation range by driving away in a low gear and by making sure that the tires are inflated.

## → E-bikes and Nm

Newton meter indicates how large the torque is. Torque is the turning force that the motor can deliver. The more torque, the more powerful the motor.

### How powerful should the engine be?

If you cycle a lot on flat terrain, with the occasional small hill, then 50 to 60 Nm meters should be sufficient, if you live / cycle a lot in hilly areas, then a stronger engine with 80 Nm is absolutely recommended, we recommend also the bafang motor for these areas.



## E-CargoBike Classic Short

The CargoBike classic short Steps is a traditional CargoBike with the Shimano Steps motor. The motor is mounted in the bottom bracket. The motor detects rotation, cadence and torque to give you smooth power assistance. Dimensions: CargoBike short: length 228cm x width 63cm.

- Black gloss
- Black matt
- Petrol blue
- Granite matt
- Blue matt
- Ivory
- Army green matt
- Orange matt
- Night blue
- Sparkle Red



## E-CargoBike Cruiser Short

A vintage version similar to the CargoBike Classic Steps, but with fat tyres for comfort, mudguards in matching frame colour, Brooks Aged leather saddle and handlebar grips, a retro style 35 lux headlight and Plateo rear light. Dimensions CargoBike short: Length 228cm x width 63cm

- Black gloss
- Black matt
- Petrol blue
- Granite matt
- Blue matt
- Ivory
- Army green matt
- Orange matt
- Night blue
- Sparkle Red



### → Available gear options

- Rollerbrakes:**  
 Shimano 5v Mechanical: **NN5**  
 Shimano 5v Di2: **NN5 Di2**  
 Shimano 7v: **NN7**
- Disc brakes:**  
 Shimano 5v Mechanical: **SS5**  
 Shimano 5v Di2: **SS5 Di2**  
 Shimano 7v: **SS7**  
 Enviolo: **SSi**
- Magura HS11 rim brakes:**  
 Shimano 5v Mechanical: **MM5**  
 Shimano 5v Di2: **MM5 Di2**  
 Shimano 7v: **MM7**  
 Enviolo: **MMi**



→ Accessories  
(See page. 30 to 35)

### → Available gear options

- Rollerbrakes:**  
 Shimano 5v Mechanical: **NN5**  
 Shimano 5v Di2: **NN5 Di2**  
 Shimano 7v: **NN7**
- Disc brakes:**  
 Shimano 5v Mechanical: **SS5**  
 Shimano 5v Di2: **SS5 Di2**  
 Shimano 7v: **SS7**  
 Enviolo: **SSi**
- Magura HS11 rim brakes:**  
 Shimano 5v Mechanical: **MM5**  
 Shimano 5v Di2: **MM5 Di2**  
 Shimano 7v: **MM7**  
 Enviolo: **MMi**

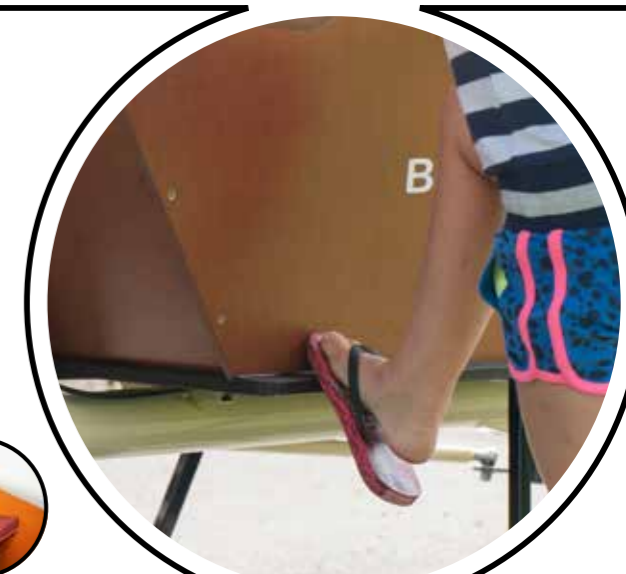

→ Accessories  
(See page. 30 to 35)



## E-CargoBike Classic Long

The CargoBike classic short Steps is a traditional CargoBike with the Shimano Steps motor. The motor is mounted in the bottom bracket. The motor detects rotation, cadence and torque to give you smooth power assistance. Due to the longer box there is more space available for accessories such as the Maxi-Cosi or an extra bench.

Dimensions CargoBike long: length 253cm x width 63cm.



## E-CargoBike Cruiser Long

Similar to the CargoBike Classic Long Steps, but a vintage version with mudguards in matching frame colour, Brooks Aged leather saddle and handlebar grips, a retro style 35 lux headlight and Plateau rear light.

Dimensions CargoBike long: Length 253cm x width 63cm



### → Available gear options

	steps	Bafang
<b>Rollerbrakes:</b>		
Shimano 5v Mechanical:	NN5	V
Shimano 5v Di2:	NN5 DI2	V
Shimano 7v:	NN7	V
<b>Disc brakes:</b>		
Shimano 5v Mechanical:	SS5	V
Shimano 5v Di2:	SS5 DI2	V
Shimano 7v:	SS7	V
Enviolo	SSi	V
<b>Magura HS11 rim brakes:</b>		
Shimano 5v Mechanical:	MM5	V
Shimano 5v Di2:	MM5 DI2	V
Shimano 7v:	MM7	V
Enviolo:	MMi	V



→ Accessories  
(See page. 30 to 35)

### → Available gear options

	steps	Bafang
<b>Rollerbrakes:</b>		
Shimano 5v Mechanical:	NN5	V
Shimano 5v Di2:	NN5 DI2	V
Shimano 7v:	NN7	V
<b>Disc brakes:</b>		
Shimano 5v Mechanical:	SS5	V
Shimano 5v Di2:	SS5 DI2	V
Shimano 7v:	SS7	V
Enviolo	SSi	V
<b>Magura HS11 rim brakes:</b>		
Shimano 5v Mechanical:	MM5	V
Shimano 5v Di2:	MM5 DI2	V
Shimano 7v:	MM7	V
Enviolo:	MMi	V



→ Accessories  
(See page. 30 to 35)



# Shadow

The Shadow is the top model from Bakfiets.nl. It has an aluminum frame, Shimano Steps mid-engine, aluminum profile box with trampoline fabric. This model is the lightest and stiffest cargobike within our product range due to the aluminium double walled spiderweb tube in the frame. This makes cycling on this cargo bike a natural experience. The hydraulic brakes and strong rims make the Shadow a very stable and safe cargobike. The dimension of the box are equal to the CargoBike Long, so most accessories will fit.

Dimensions Shadow: length 253cm x width 63cm.

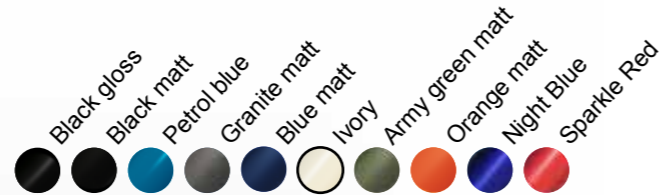

## → Available gear options

Rollerbrakes:		steps	Bafang
Shimano 5v Mechanical:	<b>NN5</b>	V	
Shimano 5v Di2:	<b>NN5 DI2</b>	V	
Shimano 7v:	<b>NN7</b>	V	
Disc brakes:			
Shimano 5v Mechanical:	<b>SS5</b>	V	
Shimano 5v Di2:	<b>SS5 DI2</b>	V	
Shimano 7v:	<b>SS7</b>	V	
Enviolo	<b>SSi</b>	V	
Magura HS11 rim brakes:			
Shimano 5v Mechanical:	<b>MM5</b>	V	
Shimano 5v Di2:	<b>MM5 DI2</b>	V	
Shimano 7v:	<b>MM7</b>	V	
Enviolo:	<b>MMi</b>	V	

→ Accessories  
(See page. 30 to 35)





## Shepherd Steps new

The Shepherd is the top model of Bakfiets.nl. With its aluminum frame, Shimano Steps mid-engine and EPP box, this model is light and super stiff. This makes cycling on this cargo bike a real experience. The aluminum frame is made of engineered double-walled aluminum tubes. The hydraulic brakes and the strong rims make the Shepherd very solid and safe. Please note, not all accessories are applicable. Sizes Shepherd: length 265cm x width 71cm.



### → Available gear options

Rollerbrakes:		steps
Shimano 5v Mechanical:	<b>NN5</b>	V
Shimano 5v Di2:	<b>NN5 Di2</b>	V
<b>Disc brakes:</b>		
Shimano 5v Mechanical:	<b>SS5</b>	V
Shimano 5v Di2:	<b>SS5 Di2</b>	V
Enviolo	<b>SSi</b>	V
<b>Magura HS11 rim brakes:</b>		
Shimano 5v Mechanical:	<b>MM5</b>	V
Shimano 5v Di2:	<b>MM5 Di2</b>	V
Enviolo:	<b>MMi</b>	V

### → Accessories



69. Canopy Shepherd



70. Coverall Shepherd



## new Shepherd Bafang

The Shepherd is the top model of Bakfiets.nl. With the Bafang model, a very stiff steel frame is mounted, and of course this bike has a powerful Bafang M400 motor and EPP box. This makes cycling on this cargo bike a real experience. The hydraulic brakes and the strong rims make the Shepherd very solid and safe. Please note, not all accessories are applicable. Sizes Shepherd: length 265cm x width 71cm.



### → Available gear options

Rollerbrakes:		Bafang
Shimano 5v Mechanical:	<b>NN5</b>	V
<b>Disc brakes:</b>		
Shimano 5v Mechanical:	<b>SS5</b>	V
Enviolo	<b>SSi</b>	V
<b>Magura HS11 rim brakes:</b>		
Shimano 5v Mechanical:	<b>MM5</b>	V
Enviolo:	<b>MMi</b>	V

The Bafang system is standard available with the big 750wh battery

### → Accessories



69. Canopy Shepherd



70. Coverall Shepherd





## E-CargoTrike Classic Narrow

The trike has more space than the Cargobike. As standard there is room for four children. One of the benefits of the trike is the stability of the bike at lower speeds. **Take note that:** a lot of people still prefer the Cargobike due to the higher maneuverability of the bike.

Dimensions trike narrow: length 210cm x width 85 cm.  
Dimensions bottom surface: length 86cm x width 54cm.



## E-CargoTrike Cruiser Narrow

The Cargotrike narrow cruiser is a trike with a modern "vintage" appearance due to its creme fat tires, retro style 35 lux headlights, Brooks Aged leather saddle and handlebar grips. All Trikes are equipped with a steering stabilizer. This provides stable steering and prevents sudden change of direction when one wheel hits a small pit.

Dimensions trike narrow: length 210cm x width 85 cm.  
Dimensions bottom surface: length 86cm x width 54cm.

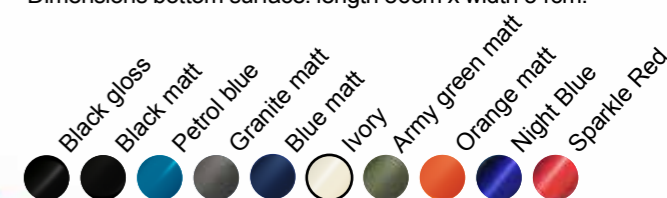

### → Available gear options

Rollerbrakes:	steps	Bafang
Shimano 5v Mechanical:	NN5	V
Shimano 5v Di2:	NN5 DI2	V
Shimano 7v:	NN7	V
Disc brakes:		
Shimano 5v Mechanical:	SS5	V
Shimano 5v Di2:	SS5 DI2	V
Shimano 7v:	SS7	V
Enviolo	SSi	V



→ Accessories  
(See page. 30 to 35)

### → Available gear options

Rollerbrakes:	steps	Bafang
Shimano 5v Mechanical:	NN5	V
Shimano 5v Di2:	NN5 DI2	V
Shimano 7v:	NN7	V
Disc brakes:		
Shimano 5v Mechanical:	SS5	V
Shimano 5v Di2:	SS5 DI2	V
Shimano 7v:	SS7	V
Enviolo	SSi	V



→ Accessories  
(See page. 30 to 35)





## E-CargoTrike Classic Wide

The wide version of the trike has a better road handling due to the bigger distance between the front weels. The bin also has a bigger capacity. There is also standard room for four children. Dimensions trike wide: length 210cm x width 95 cm. Dimensions bottom surface: length 86 cm x width 65 cm.



- Black gloss
- Black matt
- Petrol blue
- Granite matt
- Blue matt
- Ivory
- Army green matt
- Orange matt
- Night Blue
- Sparkle Red

### → Available gear options

Rollerbrakes:	steps	Bafang
Shimano 5v Mechanical:	NN5	V
Shimano 5v Di2:	NN5 DI2	V
Shimano 7v:	NN7	V
Disc brakes:		
Shimano 5v Mechanical:	SS5	V
Shimano 5v Di2:	SS5 DI2	V
Shimano 7v:	SS7	V
Enviolo	SSi	V

**Hint:**  
Order your Trike with an extremely good front disc brakes with parking brake.



→ Accessories  
(See page. 30 to 35)



## E-CargoTrike Cruiser Wide

The Cargotrike wide cruiser is a trike with a modern "vintage" appearance due to its creme fat tires, Brooks Aged leather saddle and handlebar grips and retro style 35 lux headlights. All Trikes are equipped with a steering stabilizer. **Take note off:** In the cruiser trikes the battery is mounted in the carrier (this carrier is also compatible with a child seat). Dimensions trike wide: length 210cm x width 95 cm. Dimensions bottom surface: length 86 cm x width 65 cm.



- Black gloss
- Black matt
- Petrol blue
- Granite matt
- Blue matt
- Ivory
- Army green matt
- Orange matt
- Night Blue
- Sparkle Red

### → Available gear options

Rollerbrakes:	steps	Bafang
Shimano 5v Mechanical:	NN5	V
Shimano 5v Di2:	NN5 DI2	V
Shimano 7v:	NN7	V
Disc brakes:		
Shimano 5v Mechanical:	SS5	V
Shimano 5v Di2:	SS5 DI2	V
Shimano 7v:	SS7	V
Enviolo	SSi	V

→ Accessories  
(See page. 30 to 35)







### Shimano Nexus 5 especially for E-bikes

Bakfiets.nl has chosen a number of models for the Nexus 5 hub. This hub has been specially developed for use in combination with a mid-engine. It is built more solidly than an 8-speed hub so that it can withstand more power. This hub is available with a DI2 unit (automatic shifting), and can often be combined with disc, magura and roller brake brakes

Benefits include:  
 Shifting lighter (especially when upshifting):  
 The Shimano STEPS system combined with this hub, gives a higher torque of 60Nm

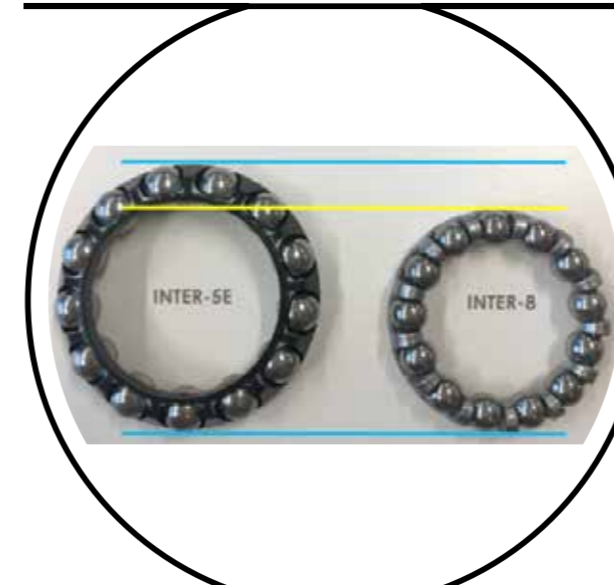

Hubs for E-BIKES equipped with a mid-engine face higher forces compared to hubs for regular bicycles. The new NEXUS INTER-5E hub can handle these forces, because it is stronger and more durable.

As can be seen on the right, the drive mechanism has a larger bearing loop rings and larger rolling bodies, as compared to the 8 speed hub. This to increase durability and strength.

The internal unit consists of 2 main parts and has 4 planet gears instead of 3, as with the other NEXUS hubs. This extra planet wheel provides more stability. This is better from a durability point of view, as the load is now distributed over 4 sprockets instead of 3. This means that each planet gear is less loaded.

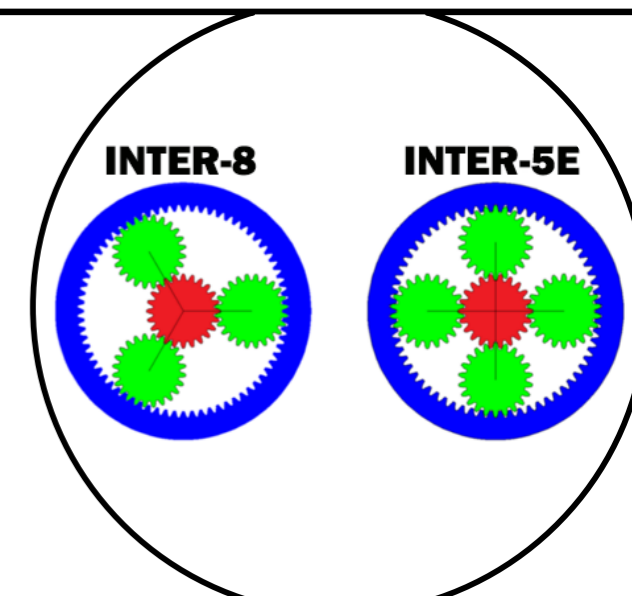

## CargoBike Classic Short

The CargoBike Classic Short is most similar to the original model, easy to steer, has a low centre of gravity and a wooden box where children can easily get in and out off. The unique four footed stand gives complete stability to the cargobike while loading and when parked. Also the magnetic safety belts are easy to use. Dimensions Cargobike short: length 228cm x width 63cm.

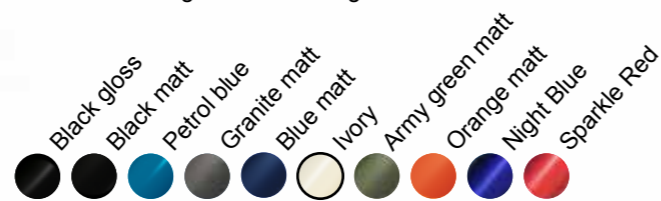

## CargoBike Cruiser Short

The CargoBike Cruiser Short is a vintage version of the Classic model with fat tyres for comfort, mudguards in matching frame colour, Brooks Aged leather saddle and handlebar grips and a retro style 35 lux headlight and Plateo rear light (both powered by the hub dynamo and with standlight function). There is no rear carrier rack fitted. Dimensions Cargobike short: Length 253cm x width 63cm

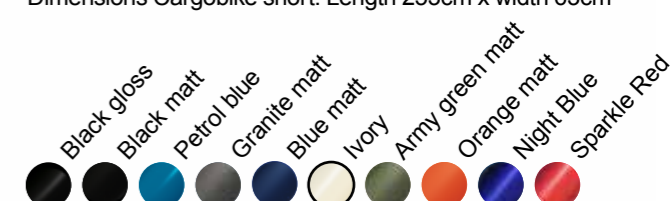

### → Available gear options

- |                                |             |
|--------------------------------|-------------|
| <b>Rollerbrakes:</b>           |             |
| Shimano 7v:                    | <b>NN7D</b> |
| Shimano 8v:                    | <b>NN8D</b> |
| Shimano 8v with coaster brake: | <b>NR8D</b> |
| <b>Discbrakes:</b>             |             |
| Shimano 7v:                    | <b>SS7D</b> |
| Enviolo:                       | <b>SSiD</b> |
| <b>Magura HS11 rim brakes:</b> |             |
| Shimano 7v:                    | <b>MM7D</b> |
| Shimano 8v:                    | <b>MM8D</b> |
| Enviolo:                       | <b>MMiD</b> |

→ For the version with electric assistance see page 4 to 5.

→ Accessories  
(See page. 30 to 35)



### → Available gear options

- |                                |             |
|--------------------------------|-------------|
| <b>Rollerbrakes:</b>           |             |
| Shimano 7v:                    | <b>NN7D</b> |
| Shimano 8v:                    | <b>NN8D</b> |
| Shimano 8v with coaster brake: | <b>NR8D</b> |
| <b>Discbrakes:</b>             |             |
| Shimano 7v:                    | <b>SS7D</b> |
| Enviolo:                       | <b>SSiD</b> |
| <b>Magura HS11 rim brakes:</b> |             |
| Shimano 7v:                    | <b>MM7D</b> |
| Shimano 8v:                    | <b>MM8D</b> |
| Enviolo:                       | <b>MMiD</b> |

→ For the version with electric assistance see page 4 to 5.

→ Accessories  
(See page. 30 to 35)



## CargoBike Classic Long

The CargoBike Classic Long is identical to the Short but with a stretched frame and box. It has the space to carry up to 3 children by adding an extra bench at the front, or 2 children on the rear bench and a baby in a Maxi Cosi or white a woolly baby/toddler seat in the front area. You can also carry a dog with a top cage or add a door in the side of the box for easy entrance. In short, there are a lot of options available.

Dimensions Cargobike long: length 253cm x width 63cm.

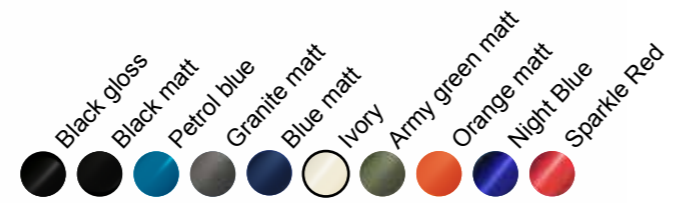

## CargoBike Cruiser Long

The CargoBike Cruiser Long is a vintage version of the Classic model with fat tyres for comfort, mudguards in matching frame colour, Brooks Aged leather saddle and handlebar grips and a retro style 35 lux headlight and Plateo rear light (both powered by the hub dynamo and with standlight function). There is no rear carrier rack fitted.

Dimensions Cargobike long: length 253cm x width 63cm.

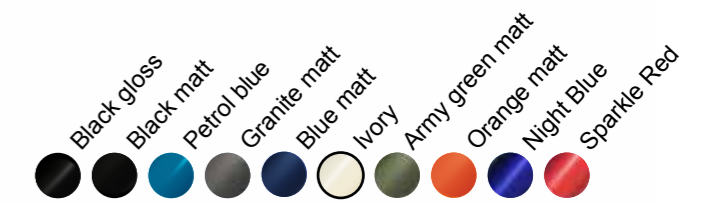

### → Available gear options

- Rollerbrakes:**
  - Shimano 7v: **NN7D**
  - Shimano 8v: **NN8D**
  - Shimano 8v with coaster brake: **NR8D**
- Discbrakes:**
  - Shimano 7v: **SS7D**
  - Enviolo: **SSiD**
- Magura HS11 rim brakes:**
  - Shimano 7v: **MM7D**
  - Shimano 8v: **MM8D**
  - Enviolo: **MMiD**

→ For the version with electric assistance see page 6 to 8.

→ Accessories (See page. 30 to 35)



### → Available gear options

- Rollerbrakes:**
  - Shimano 7v: **NN7D**
  - Shimano 8v: **NN8D**
  - Shimano 8v with coaster brake: **NR8D**
- Discbrakes:**
  - Shimano 7v: **SS7D**
  - Enviolo: **SSiD**
- Magura HS11 rim brakes:**
  - Shimano 7v: **MM7D**
  - Shimano 8v: **MM8D**
  - Enviolo: **MMiD**

→ For the version with electric assistance see page 6 to 8.

→ Accessories (See page. 30 to 35)



## CargoTrike Classic Narrow

The trike has more space than the Cargobike, it also is more stable at lower speeds. There is standard room for four children due to the two included benches. There is also a handy step on top of the mudguards to help them get in and out of the box. As an accessory there is a user friendly canopy and/ or box cover available (in two colors).

Dimensions trike narrow: length 210cm x width 85cm.  
Dimensions bottom surface: length 86cm x width 54.

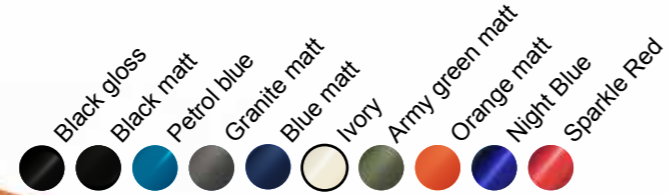

## CargoTrike Cruiser Narrow

The CargoTrike Cruiser Narrow is a vintage version of the Classic model with fat tyres for comfort, broad mudguards in matching frame colour, Brooks Aged leather saddle and handlebar grips and a retro style 35 lux headlight and Plateo rear light (both powered by the hub dynamo and with standlight function). There is no rear carrier rack fitted.

Dimensions trike narrow: length 210cm x width 85cm.  
Dimensions bottom surface: length 86cm x width 54.

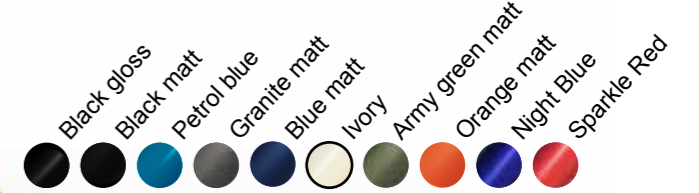

### → Available gear options

<b>Rollerbrakes:</b>	
Shimano 7v:	<b>NN7D</b>
Shimano 8v:	<b>NN8D</b>
Shimano 8v with coaster brake:	<b>NR8D</b>
<b>Discbrakes:</b>	
Shimano 7v:	<b>SS7D</b>
Enviolo:	<b>SSiD</b>
<b>Magura brake rear with rollerbrake (front):</b>	
Enviolo:	<b>NMiD</b>

→ For the version with electric assistance see page 12 to 13.

→ Accessories  
(See page. 30 to 35)



### → Available gear options

<b>Rollerbrakes:</b>	
Shimano 7v:	<b>NN7D</b>
Shimano 8v:	<b>NN8D</b>
Shimano 8v with coaster brake:	<b>NR8D</b>
<b>Discbrakes:</b>	
Shimano 7v:	<b>SS7D</b>
Enviolo:	<b>SSiD</b>
<b>Magura brake rear with rollerbrake (front):</b>	
Enviolo:	<b>NMiD</b>

→ For the version with electric assistance see page 12 to 13.

→ Accessories  
(See page. 30 to 35)



## CargoTrike Classic Wide

The CargoTrike Classic Wide is similar in length to the Narrow, but is 10cm wider so it offers even more space for freight or children. As an accessory there is a box cover and a wooden cover available. This makes the Cargotrike Wide perfect for transporting luggage.

Dimensions Trike Wide: length 210cm x width 95cm.

Dimensions bottom surface: length 86cm x width 65cm.



## CargoTrike Cruiser Wide

The CargoTrike Cruiser Wide is a vintage version of the Classic model with fat tyres for comfort, broad mudguards in matching frame colour, Brooks Aged leather saddle and handlebar grips and a retro style 35 lux headlight and Plateo rear light (both powered by the hub dynamo and with standlight function). There is no rear carrier rack fitted.

Dimensions Trike Wide: length 210cm x width 95cm.

Dimensions bottom surface: length 86cm x width 65cm.



### → Available gear options

**Rollerbrakes:**

- Shimano 7v:
- Shimano 8v:
- Shimano 8v with coaster brake:

- NN7D**
- NN8D**
- NR8D**

**Discbrakes:**

- Shimano 7v:
- Enviolo:

- SS7D**
- SSiD**

**Magura brake rear with rollerbrake (front):**

- Enviolo:

- NMiD**

→ For the version with electric assistance see page 14 to 15.

→ Accessories  
(See page. 30 to 35)



### → Available gear options

**Rollerbrakes:**

- Shimano 7v:
- Shimano 8v:
- Shimano 8v with coaster brake:

- NN7D**
- NN8D**
- NR8D**

**Discbrakes:**

- Shimano 7v:
- Enviolo:

- SS7D**
- SSiD**

**Magura brake rear with rollerbrake (front):**

- Enviolo:

- NMiD**

→ For the version with electric assistance see page 14 to 15.

→ Accessories  
(See page. 30 to 35)





## Rickshaw

Drivers and passengers can talk to each other comfortably and enjoy the surroundings in peace. The Rickshaw is a fantastic way to explore the city. This electric taxi is equipped with a Shimano Steps mid-engine. This makes it very durable and also much cheaper to use than a car (the battery is charged again for 10 cent!). The extendable footboard ensures that passengers can board safely. The Riksja is standard equipped with thick ventilating cushions. Optionally, the canopy and/or warm foot rug can be ordered. The hood not only provides protection from the sun and canopy, but also gives a cozy look.

Dimensions: Length 290cm x width 102cm

- Black gloss
- Black matt
- Petrol blue
- Granite matt
- Blue matt
- Ivory
- Army green matt
- Orange matt
- Night Blue
- Sparkle Red



### → Available gear options

Disc brakes::		steps	Bafang
Shimano 5v Mechanical:	<b>SS5</b>	V	V
Shimano 5v Di2:	<b>SS5 Di2</b>	V	V
Enviolo:	<b>SSi</b>	V	V



Optional canopy



Optional foot rug



Optional safety bracket





## Cleaner E-Trike

This Trike is ideal for cleaning companies. Whether you clean outside the roads, paths, parks or squares. With this electric Trike you can cycle everywhere in an instant, and you will have your terrain clean again in no time. The container is easy to take anywhere, and is easily removable. The container is secured with a lashing strap. Please note, the bicycle will be delivered without a container.

Sizes Cleaner Trike: length 210cm x width 105cm

- Black gloss
- Black matt
- Petrol blue
- Granite matt
- Blue matt
- Ivory
- Army green matt
- Orange matt
- Night Blue
- Sparkle Red



### → Available gear options

Disc brakes::	steps	Bafang
Shimano 5v Mechanical:	SS5	V
Shimano 5v Di2:	SS5 Di2	V
Enviolo:	SSi	V



## Daycare E-Trike

The Daycare trike can transport a maximum of six young children (age +/- 2-6 years). Its also possible to mount a child seat on the back carrier to transport one extra child. Take note that: Older, taller children take more space, meaning less space remains. has standard strong disc brakes, roll bars, two benches in the longitudinal direction and easy front entry for the children.

- Black gloss
- Black matt
- Petrol blue
- Granite matt
- Blue matt
- Ivory
- Army green matt
- Orange matt
- Night Blue
- Sparkle Red



### → Available gear options

Disc brakes::	steps	Bafang
Shimano 5v Mechanical:	SS5	V
Shimano 5v Di2:	SS5 Di2	V
Enviolo:	SSi	V



### Rail for high weight load:

Heavy loaded trikes can be fitted with a special rail system which also functions as a steering limitation. This special rail system is standard on the Rickshaw and Daycare (this option is only available for the wide versions of the trike)

## → Box options













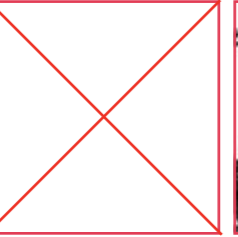

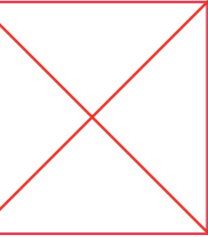

Below you will find an overview of all the different box options we offer. The business version is delivered without benches and seatbelts.

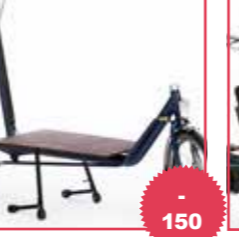
Short

Long

Trike W

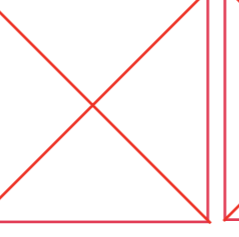
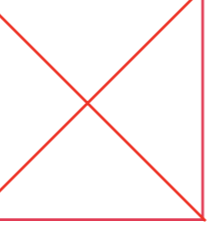
Shadow

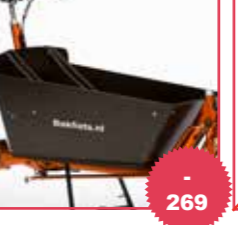
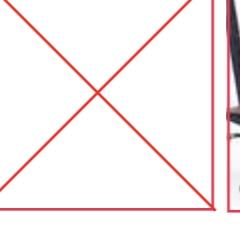
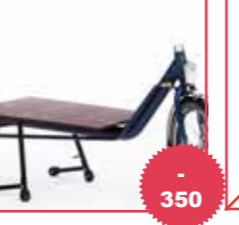
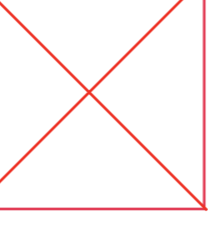
	Standaard	Bussiness	Zwarte bak	Flightcase	Bodemplaat	Aluminium
Short	 Basic	 - 20	 X	 + 929	 - 150	 X
Long	 Basic	 - 20	 + 29	 + 999	 - 150	 + 349
Trike W	 Basic	 - 40	 + 49 <i>*Please note, limited accessories fit on the black box</i>	 + 1199	 X	 X
Shadow	 Basic	 - 20	 - 269	 X	 - 350	 X

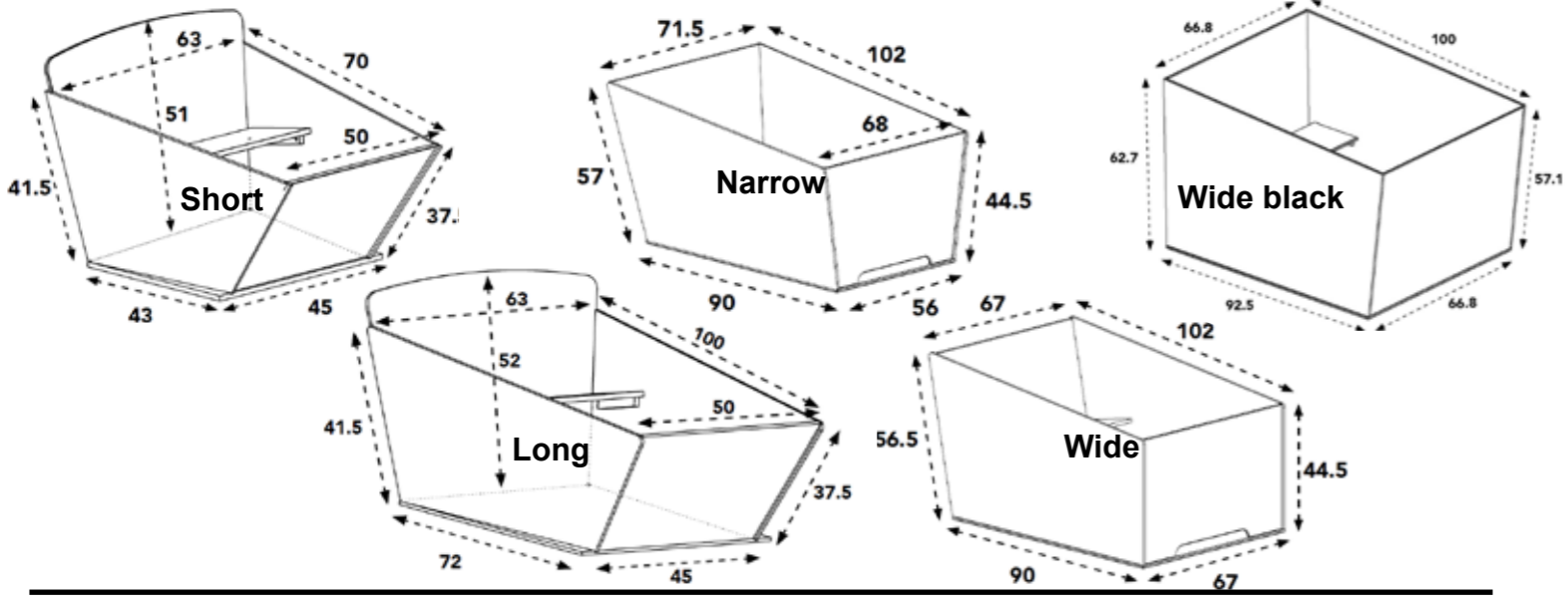

## → Options & Accessories

- Ventisit cushion single with backrest
- Ventisit cushion double with backrest
- Thick single cushion black
- Headrest
- Maxi-cosi bracket for mounting on bottom
- Maxi-cosi bracket for mounting on bench
- Black baby seat 0-9 months
- Black toddler seat 9-18 months
- Mounting bracket for baby / toddler seat
- Quick release set for baby/toddler seat
- Bracket for mounting front child seat on box bottom
- Bracket for mounting front child seat on bench
- Lock for canopy
- Renewed Maxi-cosi easy bracket
- Adaptors for Maxi-cosi easy (for mounting the Maxi-cosi easy against the back plate)
- Quick release for Maxi-cosi easy model

### Accessories CargoBike Short and Long

- Eyelet for chain / cable lock
- Extra seat on steerer tube
- Sunshade (cargobike long and short)
- Locker under bench redwood colour
- Locker under bench black wood colour
- Foldable canopy supports (CargoBike short)
- Foldable canopy supports (CargoBike long)
- Kickstand with spring function (only available as after market product)

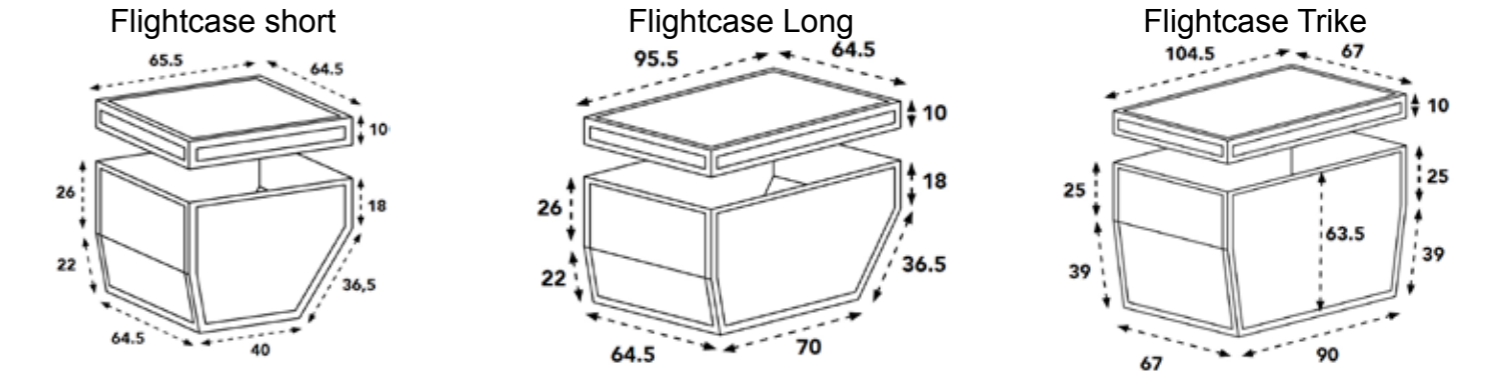



## → Options & Accessories

### Accessories CargoBike Short

- 25 Flat box cover CargoBike short: black
- 26 Canopy CargoBike short: black
- 27 Canopy CargoBike short all-open: black
- 28 Canopy CargoBike short all-open: tweed
- 29 Canopy CargoBike short all-open: black matt

### Accessories CargoBike Long

- 30 Flat box cover CargoBike long: black
- 31 Flat box cover CargoBike long: tweed
- 32 Canopy CargoBike long: black
- 33 Canopy CargoBike long all-open: black
- 34 Canopy CargoBike long all-open: tweed
- 35 Canopy CargoBike long all-open: admiral blue
- 36 Canopy CargoBike long all-open: matt black
- 37 Canopy CargoBike long all-open: red
- 38 Canopy CargoBike long all-open: brown
- 39 Canopy CargoBike long all-open: ivory matt
- 40 Ventisit cushion double
- 41 Cushion double: tweed
- 42 Cushion double: admiral blue
- 43 Cushion double: matt black
- 44 Cushion double: red
- 45 Cushion double: brown
- 46 Cushion double: ivory matt
- 47 Door panel in the side of the box (without mounting)
- 48 Dog bench and cage for CargoBike long
- 49 Ventisit floor mat (reduces unwanted noises from the box)
- 50 All-over cover CargoBike long: Black (heavy duty quality) | does not fit with canopy
- 51 Extra bench: redwood colour
- 52 Extra bench: black
- 53 Reduced bench: black (children can sit lower in the box)
- 54 Flat box cover Shadow: matt black
- 55 Canopy Shadow long all-open: matt black
- 56 All-over cover Shadow: Black (heavy duty quality) | does not fit with canopy

### Accessories Trike

- 57 Flat box cover trike: black (fits Narrow and Wide)
- 58 Canopy Trike Narrow with zipper: black
- 59 Canopy Trike Wide with zipper: black
- 60 Canopy Trike Narrow with zipper: tweed
- 61 Canopy Trike Wide with zipper: tweed
- 62 Canopy Trike Narrow with zipper: black matt
- 63 Canopy Trike Wide with zipper: black matt
- 64 Locker under bench trike (wide trike only) (without mounting)
- 65 Box lid with gas damper (wide trike only) (without mounting)
- 66 All-over cover Trike (also fits over rain tent)
- 67 Ventisit floor mat trike wide (reduces unwanted noises from the box)
- 68 Cushion double with backrest



### → The best components

Bakfiets.nl only uses the highest quality components available and works with the producers to get the best results, many of these parts are specially designed and made exclusively for us.



## A bakfiets.nl:

- Cargobike is made in Hoogeveen (Netherlands)
- Is the safest way to transport your children with a bike according to ADAC • Easy to ride and manoeuvre
- Kids can climb safely in the box because of the solid 4 leg stand
- Bakfiets.nl uses FSC approved wood
- The box is made from waterproof Phenolic coated multiplex
- The powder coating is 3 layers both durable and impact resistant
- Stainless steel components are used where possible
- Top quality accessories with upgrade options
- High resale value due to superb build quality

Bakfiets.nl thanks the following suppliers:

**SHIMANO**

**BAFANG**



**K+B BUCHEL**

**POSTERAMA**  
THE SIGNATURE ON YOUR PRODUCT

**RYDE**  
OUR WORLD

**AXA BIKE SECURITY**

**Smt**  
SMART MANUFACTURER TEAMS

**Saccon.it**

**RUBIS**



**MAGURA**

**ELVEDES**

**Bike components.**



**TWICE INTERFLEX**  
technical textile solutions

**BENGAL**  
DISC BRAKE



**ventisit**  
ventilating seat pad



**Melia.nl**

kinderstoelen voor bakfiets en fietskar



**arix**

**enviolo**

Your cargo bike dealer

Printing errors and changes reserved [www.bakfiets.nl](http://www.bakfiets.nl)